

FACTORY PARTS CATALOG ROOM AIR CONDITIONER

Frigidaire

 **Electrolux**

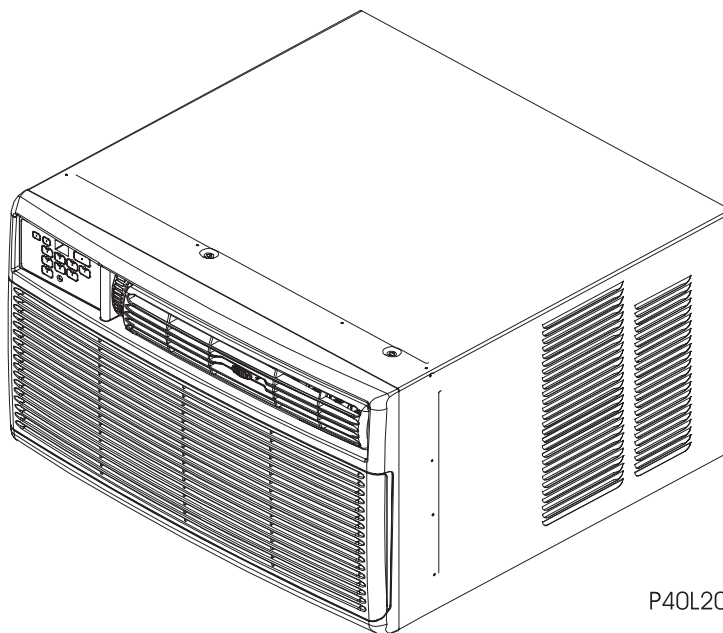

P40L2006

PRODUCT NO.	BASE MODEL NO.	SERIES	VOLTS	BTU-COOLING
FAS184M2A1	FAS184M2A	heavy duty	230	18000 BTU
MARKET				
Frigidaire				

WIRING DIAGRAM - # 309364201
OWNER'S GUIDE - # 309000848
ENERGY GUIDE - # 309369927

 **Electrolux**

ELECTROLUX HOME PRODUCTS, INC
P.O.BOX 212378, AUGUSTA, GA 30917

ROOM AIR CONDITIONER

Model No.
FAS184M2A1

Publication No.
5995384152
030114
-EN/SERVICE /KC
345

©2003 Electrolux Home Products, Inc.
All rights reserved

CABINET FRONT AND WRAPPER

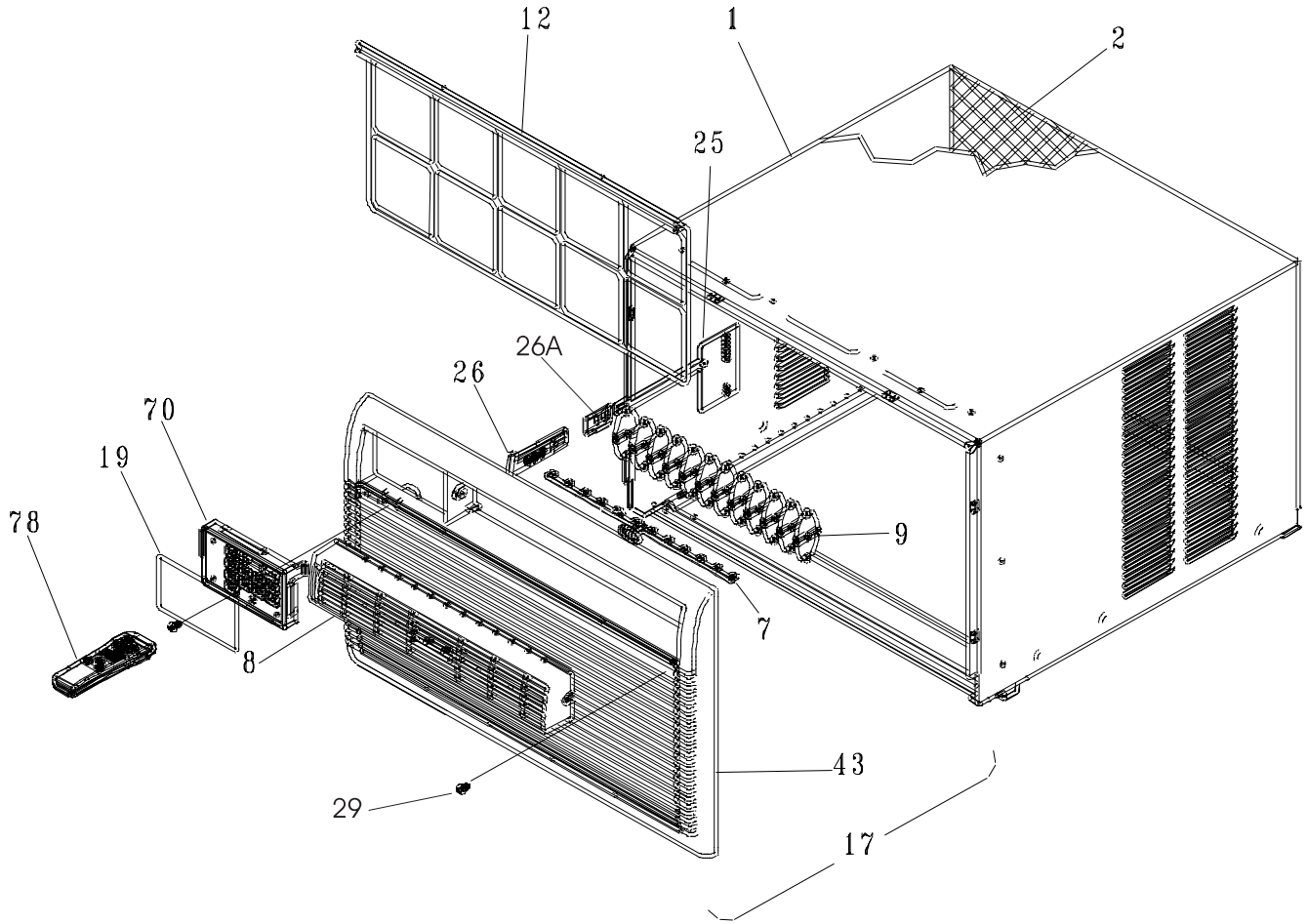

P40V2018

CABINET FRONT AND WRAPPER

POS. NO	PART NO	DESCRIPTION
1	309632704	Cabinet,sleeve ,top louvers
*	5303212504	Seal,sleeve/shroud ,23.72" x 1.25" ,bottom
2	309632804	Grille,rear ,with rail
7	309631104	Link,vertical louver ,with handle
8	309633305	Louver Assy,Incl-7,8,9
8	309630804	Louver,horizontal
9	309631004	Louver,vertical
12	309631404	Filter,air ,molded plastic
17	309633205	Front Assembly,w/7,8,9,12,43
19	309360105	Overlay,control
25	309321401	Door,vent ,with actuator
26	309330404	Handle,vent ,gray
26A	309330202	Detent,vent
29	3015312	Screw,8-18AB x 0.500
43	309630904	Panel,cabinet front
70	309369701	Enclosure,control mount
78 #	309342607	Remote Control,transmitter ,with batteries
*	309369927	Energy Guide,FAS184M2A1

CONTROLS

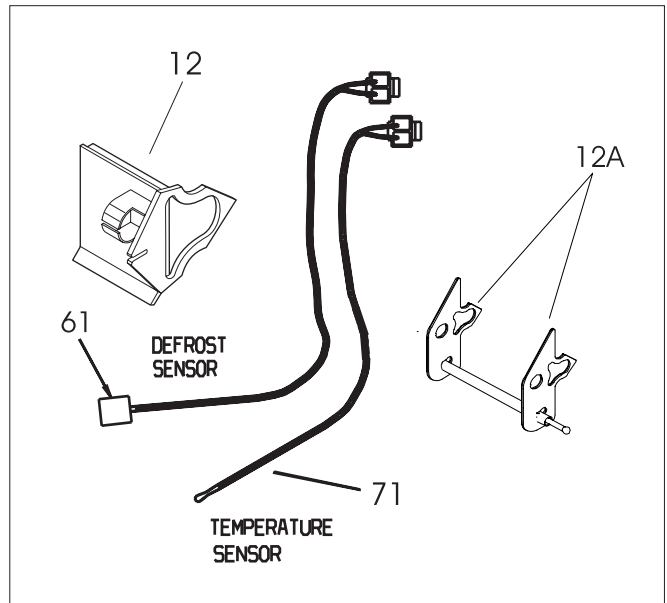
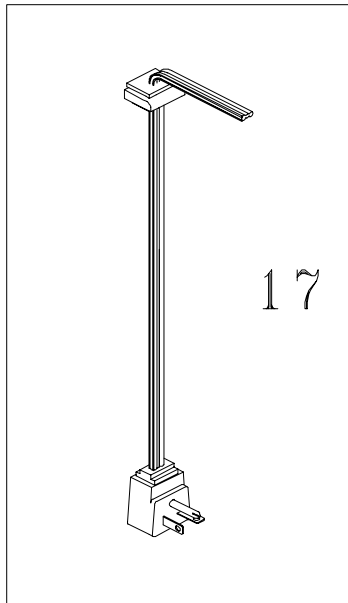
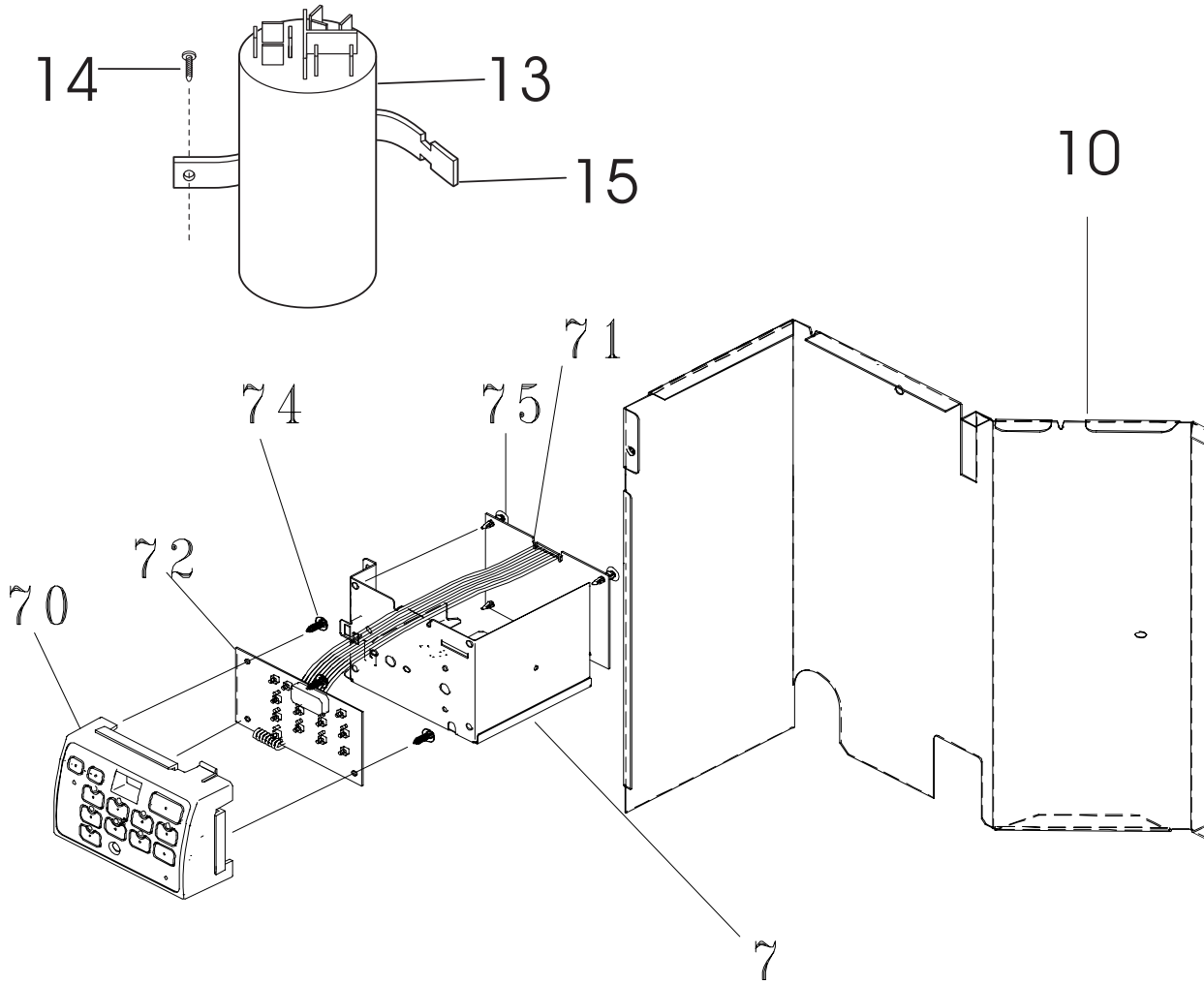

CONTROLS

POS. NO	PART NO	DESCRIPTION
7	309630403	Control Box
7*	5303015427	Screw,truss head ,8-18AB x 0.47 ,with nibs
10	309623602	Bulkhead,control system
10*	309111201	Grommet,wire protector
12	5304413782	Holder,thermistor ,w/seal
12A	309331801	Clip,sensor retainer ,(2)
13 #	5304427210	Capacitor,440 V ,25+6 microfarad
14	5303285199	Screw,Ph truss hd ,8-18 x 0.38 ,grounding
15	5303303077	Strap,capacitor mtg.
17 #	309343112	Cord-electric power,type C ,16 AWG
61 #	5304414095	Thermistor,defrost sensor
70	309369701	Enclosure,control mount
71 #	309350405	PC Board,power ,w/trans,sensor
72 #	309350407	PC Board,input
72*	5304417643	Ribbon Protector
74	5303301590	Screw,6-20AB x 0.38
75	5304413781	Hardware,PCB support

AIR HANDLING PARTS

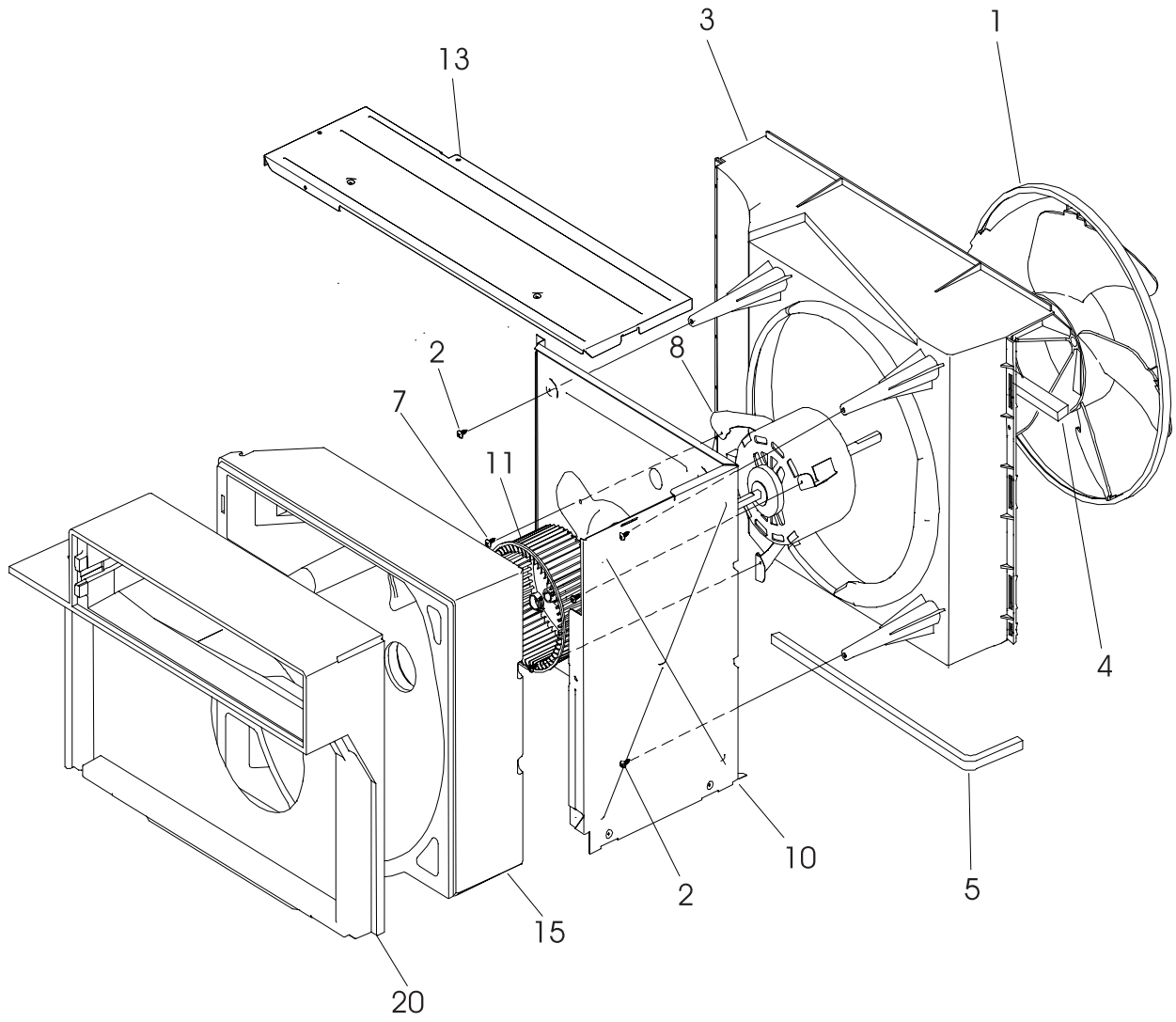

P40M2003

AIR HANDLING PARTS

POS. NO	PART NO	DESCRIPTION
1 #	5303311048	Fan Blade,with clamp
2	3202975	Screw,10-16AB x 0.72 ,square drive
3	309623201	Shroud,cond fan motor
4	5303212504	Seal,sleeve/shroud ,23.72" x 1.25" ,bottom
5	5303015311	Seal,fan housing ,19.56" x 0.50" ,lower
7	5303015427	Screw,truss head ,8-18AB x 0.47 ,with nibs
8 #	309630607	Motor,fan
10	309623401	Bulkhead,air system
11	309633001	Blower Wheel,plastic ,with clamp
13	309630302	Cover,blower wheel ,top
15	309630101	Housing,blower scroll
20	309630201	Plate,scroll cover

COMPRESSOR PARTS

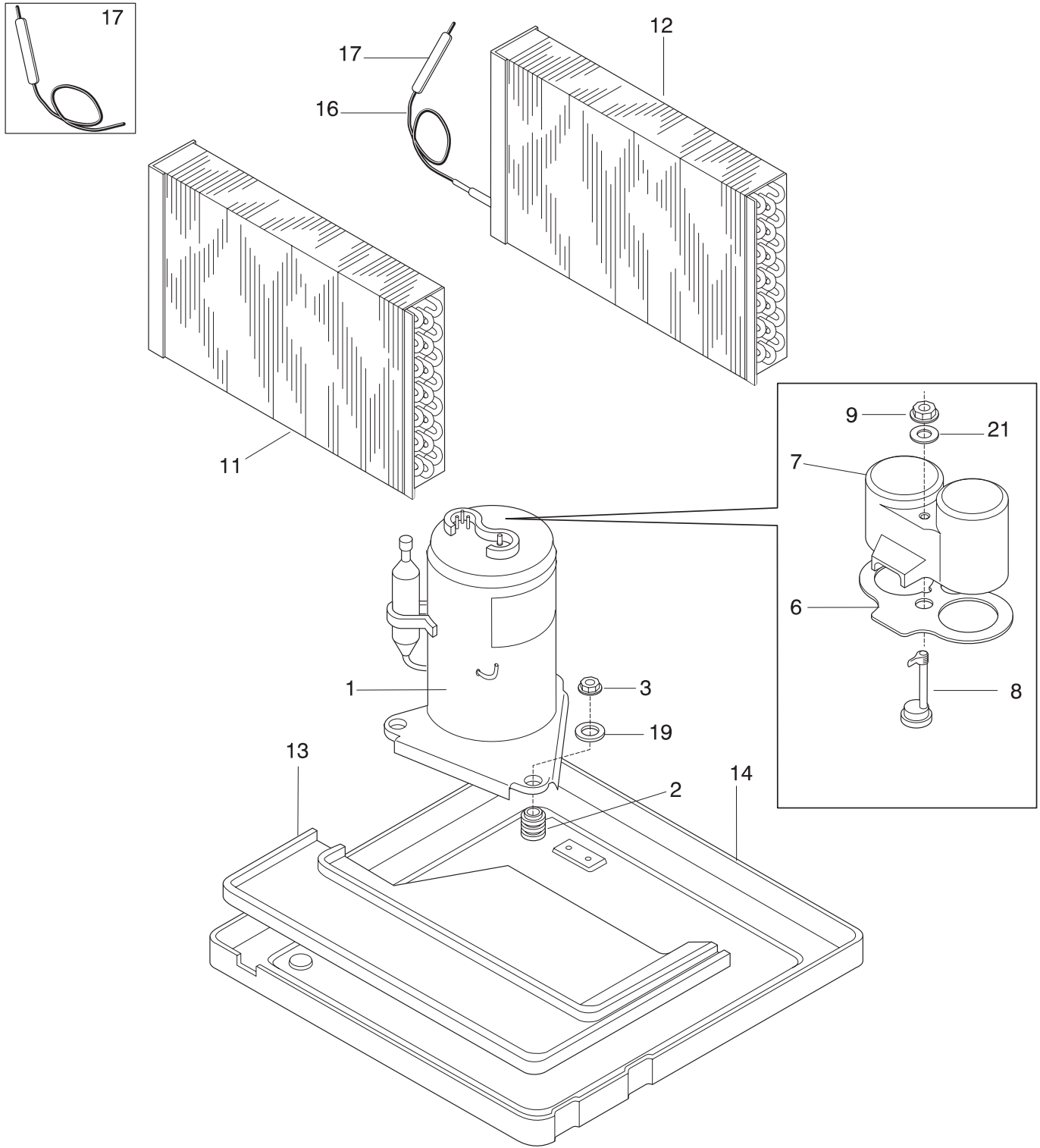

P40C2024

COMPRESSOR PARTS

POS. NO	PART NO	DESCRIPTION
1 #	309603113	Compressor
2	5303283877	Grommet,compressor mtg ,(3)
3	5308006948	Nut,compressor mtg ,(3)
6	5304431275	Gasket,terminal cover
7	5304416126	Cover,elec terminal ,compressor
8 #	5304414111	Overload Protector
9	5303294292	Nut,terminal cover
11 #	309634103	Evaporator
* #	5304414095	Thermistor,defrost sensor
12 #	5303910016	Condenser
13	309623501	Tray,evap drip
14	309632913	Base,compressor mtg. ,with studs
16 #	5304422567	Capillary Tube,33 inch long
17 #	5300265301	Drier-filter,service kit
19	309112501	Washer,metallic
21	5303293809	Washer,terminal cover

WINDOW MOUNTING PARTS

POS. NO	PART NO	DESCRIPTION
1	5304407729	Seal,window stuffer
2	5303211056	Bracket,sash lock
4	5304426345	Extension,sliding frame ,LH ,w/closure panel
5	5304409250	Seal,top rail/cab
6	5304414933	Retainer,accordian mount
7	5304414105	Bracket,support ,RH
8	3001815	Bracket,sill/unit sprt.
9	3007756	Screw,1/4-20 x 0.750
10	3007759	Nut,lock ,1/4-20 ,support bracket
11	5304414106	Bracket,support ,LH
12	3017023	Nut,hex ,10-32 ,2
13	5303281649	Screw,10-32 x 0.500 ,support
14	5304426346	Extension,sliding frame ,RH ,w/closure panel
15	5304414930	Panel,accordian ,RH/LH ,window closure
16	5304414116	Rail,top
17	3002803	Screw,wood, type 17 ,10-12 x 0.750
18	5308012680	Screw,rail
21	5303212504	Seal,sleeve/shroud ,23.72" x 1.25" ,bottom
24	3002801	Screw,8-18B x 0.500
*	309313303	Window Mounting Kit,heavy duty
*	309313204	Mounting Support Kit,heavy duty
*	5304409248	Hardware Kit>window mount ,heavy duty
*	5304409249	Seal,ship screw hole

