

# Frigidaire

## Factory Parts Catalog

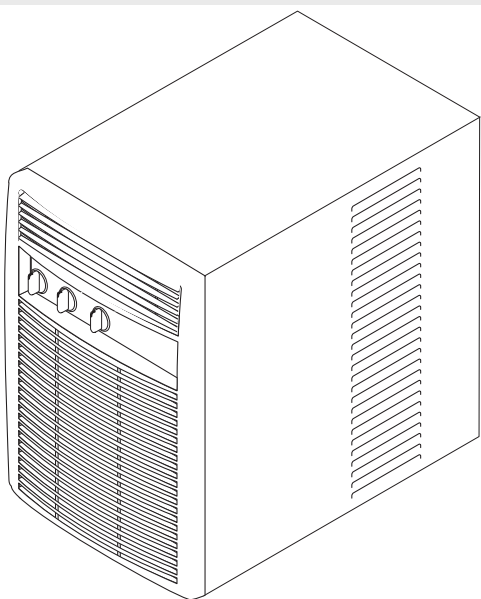

P40L2004

Product No.	FAK083N7V
Series	Slider/Casement
Volts	115
BTU-Cooling	8000
Owner's Guide	309000854
Market	North America

 **Electrolux**

ELECTROLUX HOME PRODUCTS, INC.  
P.O. Box 212378, Augusta, GA 30917

Publication No.  
**5995413126**  
04/07/14  
(EN/SERVICE/KC)  
099

**ROOM AIR  
CONDITIONER**

Model No.  
**FAK083N7**

Copyright © 2004 Electrolux Home Products, Inc.  
All rights reserved.

RECOMMENDED SPARE PARTS

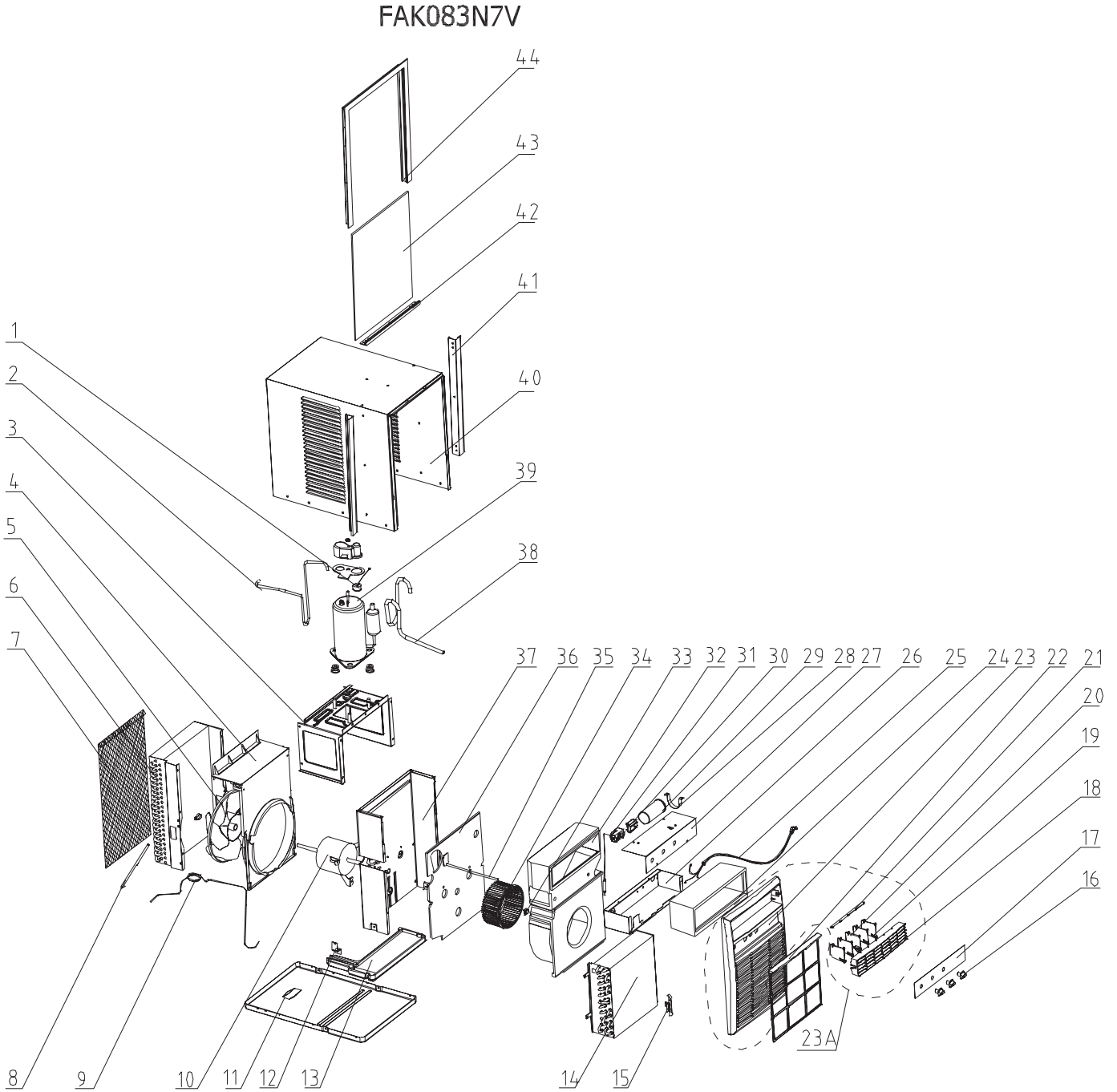

---

**RECOMMENDED SPARE PARTS**

---

POS. NO	PART NO.	DESCRIPTION
1 #	309205101	Overload Protector
2 #	309260801	Tube, discharge, formed
3	309614108	Base, compressor mtg., with studs
4	309642301	Housing, fan shroud
5 #	309626001	Fan Blade, condenser
6 #	309617311	Condenser
7	5303317604	Grille, rear
8 #	5304413933	Tube, process, cond. outlet
9 #	309375001	Tube, capillary, formed
10 #	309646002	Motor, fan
11	309621003	Base, casement unit, with seal
12	309102701	Bracket, condenser/base
13	309624101	Tray, evaporator drip
14 #	309617011	Evaporator
15	309321201	Clip, temp sensor mtg, thermostat
16	309307013	Knob, control
17	309622610	Dial Plate
18	309622204	Louver, horizontal
19	309622103	Louver, vertical
20	309622104	Louver, vertical, w/handle
21	5303303089	Link, louver
22	309622304	Filter, air, front
23	309621804	Frame, cabinet front
23A	309622404	Front Assy, complete
24	309624901	Adapter, scroll/housing, front
25 #	309343105	Cord-electric power, type A, 16 AWG
26	309606402	Control Box
27	309606501	Panel, control mount
28	5303303077	Strap, capacitor mtg.
29 #	5303306135	Capacitor, 370 V, 5+35 mfd
30 #	5303323284	Switch, selector, 7 posn, 3 speed
31 #	5303321674	Control, temperature
32	309624801	Housing, blower scroll
33	309112101	Clamp, blower wheel mt, compression
34 #	309625201	Blower Wheel, plastic
35	309625301	Door Opener, vent mechanism
36	309624601	Plate, scroll/housing, back
37	309615202	Partition, shroud/scroll, galv-steel
38 #	309261101	Tube, suction, formed
39 #	309260301	Compressor Assembly, w/electricals, 115 V, & mtg grommets
40	309622004	Cabinet, wrapper/sleeve
41	309305302	Channel, slide, side mt., (2)
42	5304414112	Retainer, window panel
43	309335102	Panel, window, 19.02 x 15.15, plastic, translucent, corrugated
44	5304414118	Frame, expander, sliding

**WIRING DIAGRAM**

